

La preziosità materica del legno massello, tre finiture di grande raffinatezza, cinque nuance calde ed avvolgenti, forme ricercate, dettagli di pregio, in una collezione di cucine che sa interpretare l'eleganza di uno stile senza tempo con la funzionalità e la praticità richieste dalla vita contemporanea. Sia che tu desideri per la tua casa un arredamento classico, sia che tu preferisca una declinazione in chiave moderna della tradizionale cucina in legno, Claudia saprà soddisfare tutte le tue esigenze.

The prized material essence of solid wood, three highly refined finishes, five warm and charming nuances, sophisticated shapes and top-quality details - all these features packed into a kitchen collection capable of blending the elegance of a timeless style with the contemporary need for functionality and practicality. Whether you desire a classical feel for your home furnishings, or a more modern interpretation of the traditional wooden kitchen, Claudia can satisfy all your needs.



nel cuore della casa

# Claudia



## LUBE ECOLOGIC

IL GRUPPO LUBE HA SCELTO DI UTILIZZARE PER I COMPONENTI COSTITUENTI LE STRUTTURE DELLE CUCINE SOLO MATERIALE A BASSISSIMA EMISSIONE DI FORMALDEIDE: CONFORMI ALLO STANDARD F4STELLE SECONDO LA NORMA JIS, CERTIFICATO DAL MINISTERO GIAPPONESE, IL PIU' SEVERO IN MERITO ALLE NORMATIVE DI SALVAGUARDIA AMBIENTALE.

Regarding the production of its kitchen structure components, lube group has decided to only use materials featuring very low formaldehyde emissions complying with the 4-star standard, as defined by the jis regulation. This standard is certified by the japanese government-the most rigorous when it comes to environmental protection.



**SP. 24 MM**

## CARATTERISTICHE TECNICHE

ANTE	intelaiata sp.24 mm in massello di frassino con pannello impiallacciato frassino con fresate orizzontali nei colori: tinto noce spazzolato (opz.561), panna decapè spazzolato (opz.564), corda decapè spazzolato (opz.566), argilla decapè spazzolato (opz.567), laccato bianco (opz.569)
ANTE CON GRATA	disponibili nelle misure 71,7x44,6 - 71,7x59,6 - 35,7x44,6 - 35,7x59,6 - 35,7x89,6 nei colori: tinto noce spazzolato (opz.561G), panna decapè spazzolato (opz.564G), corda decapè spazzolato (opz.566G), argilla decapè spazzolato (opz.567G), laccato bianco (opz.569G)
FRONTALI CASSETTI	in massello di frassino liscio sp.24 mm nei colori: tinto noce spazzolato (opz.561), panna decapè spazzolato (opz.564), corda decapè spazzolato (opz.566), argilla decapè spazzolato (opz.567), laccato bianco (opz.569)
ANTE VETRO di serie	<b>VETRO MOLATO SATINATO SP.4 MM</b> telaio sp.24 mm in massello di frassino nelle finiture: tinto noce spazzolato (opz.561M), panna decapè spazzolato (opz.564M), corda decapè spazzolato (opz.566M), argilla decapè spazzolato (opz.567M), laccato bianco (opz.569M)
ANTE VETRO a richiesta	<b>VETRO SERIGRAFATO BIANCO E DECORO FLOREALE SP.4 MM</b> telaio sp.24 mm in massello di frassino nelle finiture: tinto noce spazzolato (opz.561D), panna decapè spazzolato (opz.564D), corda decapè spazzolato (opz.566D), argilla decapè spazzolato (opz.567D), laccato bianco (opz.569D)  <b>VETRO ANTICO "F" SP.4 MM TELAIO CON INGLESINA</b> telaio sp.24 mm in massello di frassino nelle finiture: tinto noce spazzolato (opz.561I), panna decapè spazzolato (opz.564I), corda decapè spazzolato (opz.566I), argilla decapè spazzolato (opz.567I), laccato bianco (opz.569I)
MANIGLIE	<b>di serie per ante noce e panna decapè: 224 finitura argento antico passo mm 128 per anta L 15 pomo finitura argento antico 224P</b>  a richiesta: 225 finitura argento antico passo mm 128 per anta L 15 pomo finitura argento antico 224P  230 finitura argento antico passo mm 128 per anta L 15 pomo finitura argento antico 224P  155 finitura argento antico passo mm 96 per anta L 15 pomo finitura argento antico 224P  185 finitura ottone vecchio passo mm 96 per anta L 15 pomo finitura ottone vecchio 228P  186 finitura ottone vecchio passo mm 96 per anta L 15 pomo finitura ottone vecchio 228P  222 finitura rame antico inserto avorio passo mm 128 per anta L 15 pomo finitura rame antico 222P          251 finitura nichel nero satinato lucido passo mm 160 per anta L 15 passo mm 96  620 pomo in ceramica colore avorio



## CARATTERISTICHE TECNICHE

### MANIGLIE

di serie per ante corda, argilla e laccata bianca: F482 finitura cromo passo mm 160  
per anta L 15 passo mm 64

a richiesta: 244 finitura cromo passo mm 160  
per anta L 15 pomo finitura cromo 244P

242 finitura satinata passo mm 160  
per anta L 15 pomo finitura satinata 242P

246 finitura canna di fucile con swarovski centrali passo mm 160  
per anta L 15 maniglia 246/1 passo mm 32

248 finitura bronzo scuro passo mm 160  
per anta L 15 passo mm 64

### STRUTTURE

ANTA: tinto noce spazzolato  
nobilitato rovere savoyen (opz.023), schiena e ripiano avorio (opz.930)

ANTA: panna decapè spazzolato  
nobilitato panna decapè (opz.564), schiena e ripiano avorio (opz.930)

ANTA: corda decapè spazzolato  
nobilitato corda decapè (opz.566), schiena e ripiano avorio (opz.930)

ANTA: argilla decapè spazzolato  
nobilitato argilla decapè (opz.567), schiena e ripiano avorio (opz.930)

ANTA: laccato bianco  
nobilitato bianco camelia (opz.606), schiena e ripiano avorio (opz.930)



### MENSOLE

di serie: altezza 3,8 cm in laminato rovere savoyen (opz.023), panna decapè (opz.564), corda decapè (opz.566), argilla decapè (opz.567), bianco camelia (opz.606)

a richiesta: altezza 3,8 cm impiallacciate tinto noce spazzolato (opz.561), panna decapè spazzolato (opz.564), corda decapè spazzolato (opz.566), argilla decapè spazzolato (opz.567), laccato bianco (opz.569)

### ZOCCOLI

altezza 15 cm in pvc ricoperti in melamina nei colori: tinto noce (opz.561), panna decapè (opz.564), corda decapè (opz.566), argilla decapè (opz.567), laccato bianco (opz.569)









## TECHNICAL FEATURES

### HANDLES

**standard:** for jute, clay and white lacquer doors: F482 chrome finish centre-to-centre distance 160 mm  
for door W 15 with 64 mm gap

**on request:** 244 chrome finish centre-to-centre distance 160 mm  
for door W 15 chrome finish knob hole 244P

242 satin finish centre-to-centre distance 160 mm  
for door W 15 satin finish knob hole 242P

246 gunmetal grey finish with central swarovski crystals centre-to-centre distance 160 mm  
for door W 15 handle 246/1 centre-to-centre distance 32 mm

248 dark bronze finish centre-to-centre distance 160 mm  
for door W 15 centre-to-centre distance 64 mm

### STRUCTURES

**DOOR: brushed walnut-stained**  
melamine-coated savoyen oak (code 023), ivory back panel and shelf (code 930)

**DOOR: brushed pickled cream**  
melamine-coated pickled cream (code 564), ivory back panel and shelf (code 930)

**DOOR: brushed pickled jute**  
melamine-coated pickled jute (code 566), ivory back panel and shelf (code 930)

**DOOR: brushed pickled clay**  
melamine-coated pickled clay (code 567), ivory back panel and shelf (code 930)

**DOOR: white lacquer**  
melamine-coated camellia white (code 606), ivory back panel and shelf (code 930)

### SHELVES

**standard:** height 3.8 cm in savoyen oak laminate (code 023), pickled cream (code 564), pickled jute (code 566), pickled clay (code 567), camellia white (code 606)

**on request:** height 3.8 cm veneered in brushed walnut-stained (code 561), brushed pickled cream (code 564), brushed pickled jute (code 566),  
brushed pickled clay (code 567), white lacquer (code 569)

### PLINTHS

height 15 cm in PVC coated with melamine in the following colours: walnut-stained (code 561), pickled cream (code 564), pickled jute (code 566),  
pickled clay (code 567), white lacquer (code 569)

cod. **408**

**SP. 24 MM TH. 24 MM**

*Claudia*

ante in frassino tinto noce spazzolato doors in brushed walnut-stained ash

**SP. 24 MM**



**anta (opz.561)**  
door (code 561)



**anta con grata (opz.561G)**  
door with grating (code 561G)

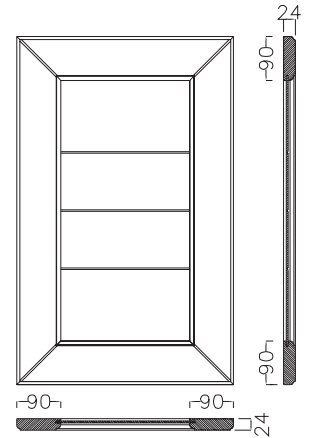

**frontale cestone (opz.561)**  
deep drawer front panel (code 561)



**frontale cestone con grata (opz.561G)**  
deep drawer front panel with grating (code 561G)



**frontale cassetto (opz.561)**  
drawer front panel (code 561)

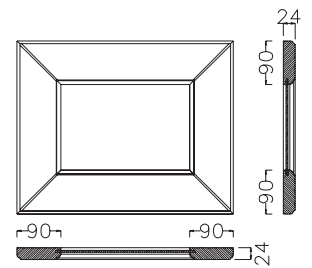

ante vetro in frassino tinto noce spazzolato glass doors in brushed walnut-stained ash

**SP. 24 MM**



**vetro molato satinato (opz.561M)**  
bevelled and frosted glass (code 561M)



**vetro serigrafato (opz.561D)**  
serigraph glass (code 561D)



**inglesina con vetro antico "F" (opz.561I)**  
glass panels with antique glass "F" (code 561I)

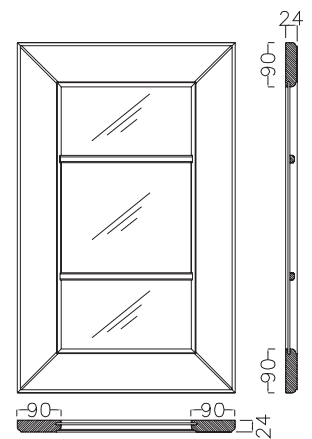

**disegno anta vetro con inglesina, vetro antico "F"**  
glass door drawing with glass panels, antique glass "F"



**cestone con vetro molato satinato (opz.561M)**  
deep drawer with bevelled and frosted glass (code 561M)



**cestone con vetro serigrafato (opz.561D)**  
deep drawer with serigraph glass (code 561D)



**cestone con vetro antico "F" (opz.561I)**  
deep drawer with antique glass "F" (code 561I)

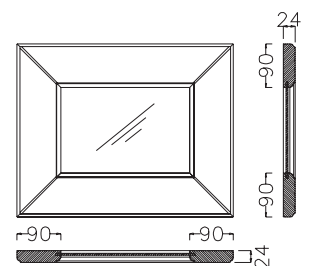

cod. **408**

**SP. 24 MM TH. 24 MM**

*Claudia*

ante in frassino panna decapè spazzolato doors in brushed pickled cream ash

**SP. 24 MM**



**anta (opz.564)**  
door (code 564)



**anta con grata (opz.564G)**  
door with grating (code 564G)

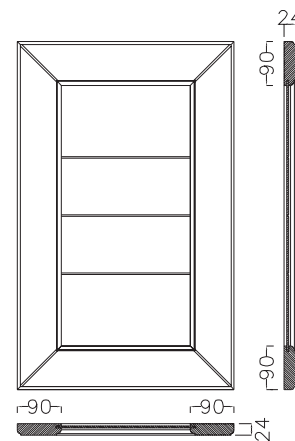

**frontale cestone (opz.564)**  
deep drawer front panel  
(code 564)



**frontale cestone con grata (opz.564G)**  
deep drawer front panel  
with grating (code 564G)



**frontale cassetto (opz.564)**  
drawer front panel (code 564)

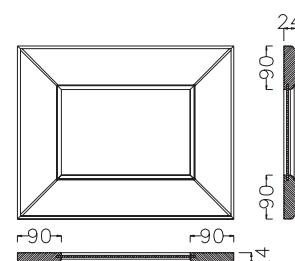

ante vetro in frassino panna decapè spazzolato glass doors in brushed pickled cream ash

**SP. 24 MM**



**vetro molato satinato (opz.564M)**  
bevelled and frosted glass  
(code 564M)



**vetro serigrafato (opz.564D)**  
serigraph glass (code 564D)



**inglesina con vetro antico "F" (opz.564I)**  
glass panels with antique  
glass "F" (code 564I)

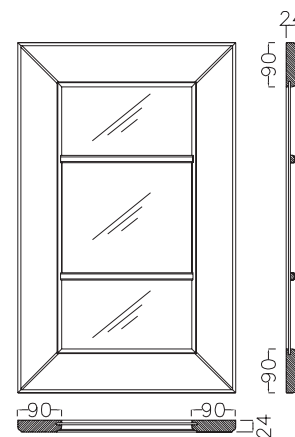

**disegno anta vetro con inglesina, vetro antico "F"**  
glass door drawing with glass  
panels, antique glass "F"



**cestone con vetro molato satinato (opz.564M)**  
deep drawer with bevelled  
and frosted glass (code 564M)



**cestone con vetro serigrafato (opz.564D)**  
deep drawer with serigraph  
glass (code 564D)



**cestone con vetro antico "F" (opz.564I)**  
deep drawer with antique  
glass "F" (code 564I)

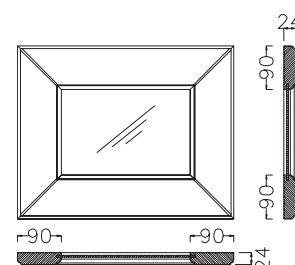

cod. **408**

**SP. 24 MM TH. 24 MM**

*Claudia*

ante in frassino corda decapè spazzolato doors in brushed pickled jute ash

**SP. 24 MM**



**anta (opz.566)**  
door (code 566)



**anta con grata (opz.566G)**  
door with grating (code 566G)

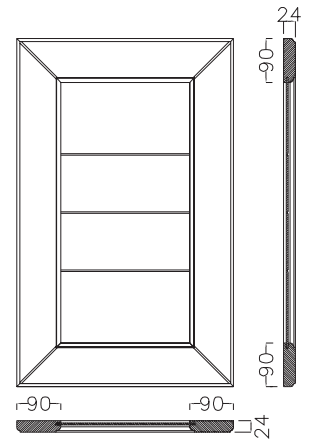

**frontale cestone (opz.566)**  
deep drawer front panel  
(code 566)



**frontale cestone con grata (opz.566G)**  
deep drawer front panel  
with grating (code 566G)



**frontale cassetto (opz.566)**  
drawer front panel (code 566)

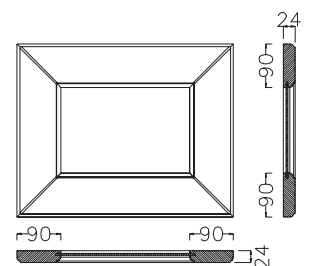

ante vetro in frassino corda decapè spazzolato glass doors in brushed pickled jute ash

**SP. 24 MM**



**vetro molato satinato (opz.566M)**  
bevelled and frosted glass  
(code 566M)



**vetro serigrafato (opz.566D)**  
serigraph glass (code 566D)



**inglesina con vetro antico "F" (opz.566I)**  
glass panels with antique  
glass "F" (code 566I)

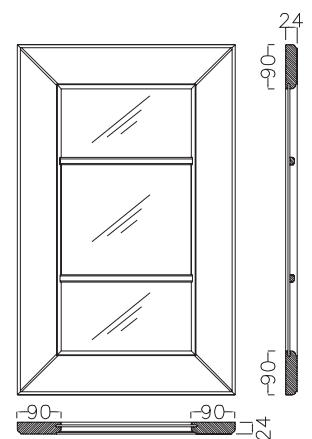

**disegno anta vetro con inglesina, vetro antico "F"**  
glass door drawing with glass  
panels, antique glass "F"



**cestone con vetro molato satinato (opz.566M)**  
deep drawer with bevelled  
and frosted glass (code 566M)



**cestone con vetro serigrafato (opz.566D)**  
deep drawer with serigraph  
glass (code 566D)



**cestone con vetro antico "F" (opz.566I)**  
deep drawer with antique  
glass "F" (code 566I)

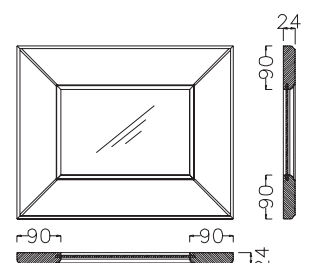



cod. **408**

**SP. 24 MM TH. 24 MM**

*Claudia*

ante in frassino argilla decapè spazzolato doors in brushed pickled clay ash

**SP. 24 MM**



**anta (opz.567)**  
door (code 567)



**anta con grata (opz.567G)**  
door with grating (code 567G)

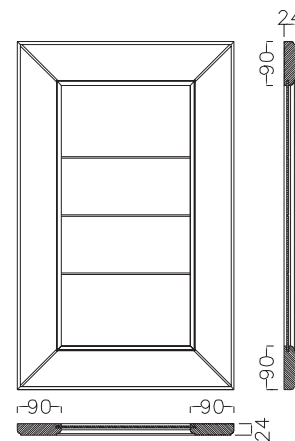

**frontale cestone (opz.567)**  
deep drawer front panel  
(code 567)



**frontale cestone con grata (opz.567G)**  
deep drawer front panel  
with grating (code 567G)



**frontale cassetto (opz.567)**  
drawer front panel (code 567)

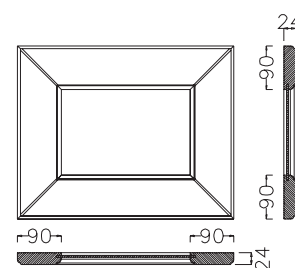

ante vetro in frassino argilla decapè spazzolato glass doors in brushed pickled clay ash

**SP. 24 MM**



**vetro molato satinato (opz.567M)**  
bevelled and frosted glass  
(code 567M)



**vetro serigrafato (opz.567D)**  
serigraph glass (code 567D)



**inglesina con vetro antico "F" (opz.567I)**  
glass panels with antique  
glass "F" (code 567I)

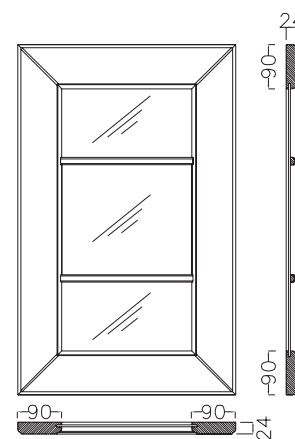

**disegno anta vetro con inglesina, vetro antico "F"**  
glass door drawing with glass  
panels, antique glass "F"



**cestone con vetro molato satinato (opz.567M)**  
deep drawer with bevelled  
and frosted glass (code 567M)



**cestone con vetro serigrafato (opz.567D)**  
deep drawer with serigraph  
glass (code 567D)



**cestone con vetro antico "F" (opz.567I)**  
deep drawer with antique  
glass "F" (code 567I)

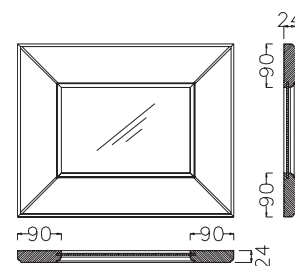

cod. **408**

**SP. 24 MM TH. 24 MM**

*Claudia*

ante in frassino spazzolato laccato bianco doors in brushed white lacquer ash

**SP. 24 MM**



**anta (opz.569)**  
door (code 569)



**anta con grata (opz.569G)**  
door with grating (code 569G)

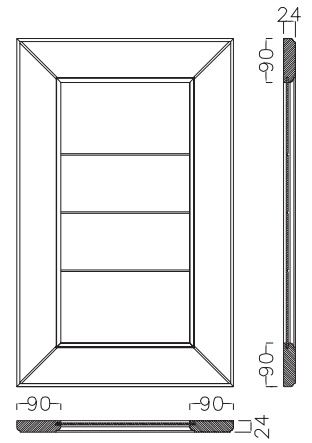

**frontale cestone (opz.569)**  
deep drawer front panel  
(code 569)



**frontale cestone con grata (opz.569G)**  
deep drawer front panel  
with grating (code 569G)



**frontale cassetto (opz.569)**  
drawer front panel (code 569)

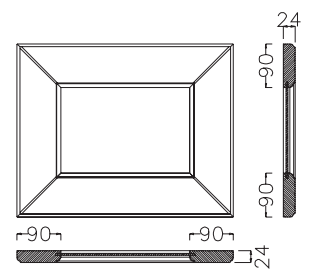

ante vetro in frassino spazzolato laccato bianco glass doors in brushed white lacquer ash

**SP. 24 MM**



**vetro molato satinato (opz.569M)**  
bevelled and frosted glass  
(code 569M)



**vetro serigrafato (opz.569D)**  
serigraph glass (code 569D)



**inglesina con vetro antico "F" (opz.569I)**  
glass panels with antique  
glass "F" (code 569I)

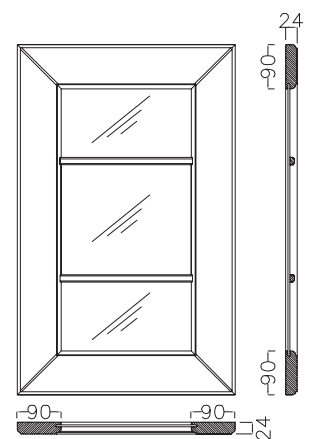

**disegno anta vetro con inglesina, vetro antico "F"**  
glass door drawing with glass  
panels, antique glass "F"



**cestone con vetro molato satinato (opz.569M)**  
deep drawer with bevelled  
and frosted glass (code 569M)



**cestone con vetro serigrafato (opz.569D)**  
deep drawer with serigraph  
glass (code 569D)



**cestone con vetro antico "F" (opz.569I)**  
deep drawer with antique  
glass "F" (code 569I)

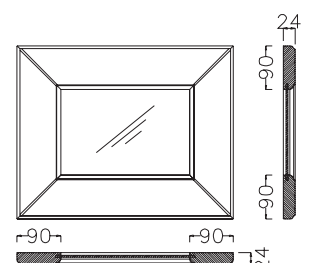

 [CLICCA QUI PER LA GAMMA DEI VETRI TELAIO ALLUMINIO](#)

 [CLICK HERE FOR THE RANGE OF ALUMINIUM FRAMED GLASS](#)

---





cod. **408**

*Claudia*

**elementi da 15 con piastrelle 10x10**

15 cm elements with 10x10 tiles

---



telaio corda decapè  
con piastrelle travertino noce  
pickled jute frame with walnut  
travertine tiles



telaio tinto noce  
con piastrelle scabas  
walnut-stained frame with  
scabas tiles

Serie: SASSI DEL PIAVE

Range: SASSI DEL PIAVE



botticino  
(opz.120)  
botticino



travertino noce  
(opz.125)  
walnut travertine



scabas  
(opz.110)  
scabas



giallo dorè  
(opz.112)  
golden yellow



travertino chiaro  
(opz.127)  
light travertine

cod. **408**

**elementi da 15 con fresata**

15 cm elements with groove

---

*Claudia*



tinto noce spazzolato (opz.561)  
brushed walnut-stained (code 561)



panna decapè spazzolato (opz.564)  
brushed pickled cream (code 564)



corda decapè spazzolato (opz.566)  
brushed pickled jute (code 566)



argilla decapè spazzolato (opz.567)  
brushed pickled clay (code 567)



laccato bianco (opz.569)  
white lacquer (code 569)

## strutture carcasses



rovere savoyen (opz.023)  
schiena e ripiano avorio (opz.930)  
savoyen oak (code 023)  
ivory back panel and shelf (code 930)



panna decapè (opz.564)  
schiena e ripiano avorio (opz.930)  
pickled cream (code 564)  
ivory back panel and shelf (code 930)



corda decapè (opz.566)  
schiena e ripiano avorio (opz.930)  
pickled jute (code 566)  
ivory back panel and shelf (code 930)



argilla decapè (opz.567)  
schiena e ripiano avorio (opz.930)  
pickled clay (code 567)  
ivory back panel and shelf (code 930)



bianco camelia (opz.606)  
schiena e ripiano avorio (opz.930)  
camellia white (code 606)  
ivory back panel and shelf (code 930)



### LUBE ECOLOGIC

IL GRUPPO LUBE HA SCELTO DI UTILIZZARE PER I COMPONENTI COSTITUENTI LE STRUTTURE DELLE CUCINE SOLO MATERIALE A BASSISSIMA EMISSIONE DI FORMALDEIDE: CONFORMI ALLO STANDARD F4\*\*\* SECONDO LA NORMA JIS, CERTIFICATO DAL MINISTERO GIAPPONESE. IL PIÙ SEVERO IN MERITO ALLE NORMATIVE DI SALVAGUARDIA AMBIENTALE.

Regarding the production of its kitchen structure components, lube group has decided to only use materials featuring very low formaldehyde emissions complying with the 4-star standard, as defined by the jis regulation. This standard is certified by the japanese government-the most rigorous when it comes to environmental protection.

## mensole in laminato laminate shelves



rovere savoyen (opz.023)  
savoyen oak (code 023)



panna decapè (opz.564)  
pickled cream (code 564)



corda decapè (opz.566)  
pickled jute (code 566)

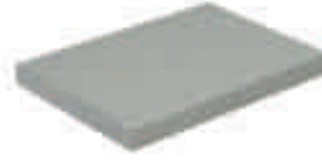

argilla decapè (opz.567)  
pickled clay (code 567)



bianco camelia (opz.606)  
camellia white (code 606)

## mensole impialacciate veneered shelves



tinto noce spazzolato (opz.561)  
brushed walnut-stained  
(code 561)



panna decapè spazzolato (opz.564)  
brushed pickled cream (code 564)



corda decapè spazzolato (opz.566)  
brushed pickled jute (code 566)

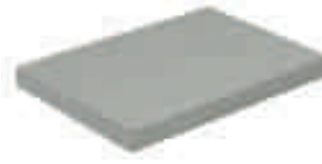

argilla decapè spazzolato (opz.567)  
brushed pickled clay (code 567)



laccato bianco (opz.569)  
white lacquer (code 569)

## zoccoli in pvc H 15 pvc plinths H 15



tinto noce (opz.561)  
walnut-stained (code 561)



panna decapè (opz.564)  
pickled cream (code 564)



corda decapè (opz.566)  
pickled jute (code 566)



argilla decapè (opz.567)  
pickled clay (code 567)



laccato bianco (opz.569)  
white lacquer (code 569)

## cornici cappello top cornices



tinto noce (opz.561)  
walnut-stained (code 561)



panna decapè (opz.564)  
pickled cream (code 564)



corda decapè (opz.566)  
pickled jute (code 566)



argilla decapè (opz.567)  
pickled clay (code 567)



laccato bianco (opz.569)  
white lacquer (code 569)

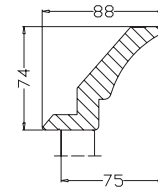

disegno cornice  
design cornice



## MANIGLIE CLASSICHE CLASSIC HANDLES

# Claudia

### DI SERIE STANDARD



Maniglia 224 finitura argento antico  
passo 128 mm

Handle 224 with antique silver finish  
centre-to-centre distance 128 mm

### A RICHIESTA ON REQUEST



Maniglia 225 finitura argento antico  
passo 128 mm

Handle 225 with antique silver finish  
centre-to-centre distance 128 mm



Maniglia 230 finitura argento antico  
passo 128 mm

Handle 230 with antique silver finish  
centre-to-centre distance 128 mm



Pomo 620 in ceramica colore avorio

Knob hole 620 in ivory ceramic finish



Maniglia 155 finitura argento antico  
passo 96 mm

Handle 155 with antique silver finish  
centre-to-centre distance 96 mm



Pomo 224P finitura argento antico  
utilizzata per elementi da 15  
con maniglia 224, 225, 155, 230

Knob hole 224P with antique silver finish  
used for 15 cm elements with handles  
224, 225, 155, 230



Maniglia 222 finitura rame antico  
inserto avorio  
passo 128 mm

Handle 222 with antique copper  
finish and ivory insert  
centre-to-centre distance 128 mm



Pomo 222P finitura rame antico  
utilizzata per elementi da 15  
con maniglia 222

Knob hole 222P with antique copper finish  
used for 15 cm elements with handle 222



Maniglia 185 finitura ottone vecchio  
passo 96 mm

Handle 185 with old brass finish  
centre-to-centre distance 96 mm



Maniglia 186 finitura ottone vecchio  
passo 96 mm

Handle 186 with old brass finish  
centre-to-centre distance 96 mm



Pomo 228P finitura ottone vecchio  
utilizzata per elementi da 15  
con maniglia 185, 186

Knob hole 228P with old brass finish used  
for 15 cm elements with handles 185, 186



Maniglia 251 finitura nichel nero  
satinato lucido  
passo 160 mm  
passo 96 mm per anta L 15

Handle 251 with polished satin-finish  
black nickel finish  
centre-to-centre distance 160 mm  
centre-to-centre distance 96 mm for door W15

## MANIGLIE MODERNE MODERN HANDLES

# Claudia

### DI SERIE STANDARD



**Maniglia F482 finitura cromo**  
passo 160 mm  
per anta L 15 passo 64 mm

Handle F482 chrome finish  
centre-to-centre distance 160 mm  
used for 15 cm centre-to-centre distance 64 mm

### A RICHIESTA ON REQUEST



**Maniglia 248 finitura bronzo scuro**  
passo 160 mm  
per anta L 15 passo 64 mm

Handle 248 dark bronze finish  
centre-to-centre distance 160 mm  
used for 15 cm centre-to-centre distance 64 mm



**Maniglia 244 finitura cromo**  
passo 160 mm

Handle 244 chrome finish  
centre-to-centre distance 160 mm



**Pomo 244P finitura cromo**  
utilizzata per elementi da 15 con maniglia 244

Knob hole 244P chrome finish  
used for 15 cm elements with handle 244



**Maniglia 242 finitura satinata**  
passo 160 mm

Handle 242 satin finish  
centre-to-centre distance 160 mm



**Pomo 242P finitura satinata**  
utilizzata per elementi da 15 con maniglia 242

Knob hole 242P satin finish  
used for 15 cm elements with handle 242



**Maniglia 246 finitura canna di fucile**  
con swarovsky centrali  
passo 160 mm

Handle 246 gunmetal grey finish with  
central swarovsky crystals  
centre-to-centre distance 160 mm



**Maniglia 246/1 finitura canna di fucile**  
passo 32 mm  
utilizzata per elementi da 15 con maniglia 246

Handle 246/1 with gunmetal grey finish  
centre-to-centre distance 32 mm  
used for 15 cm elements with handle 246



**APERTURA VERTICALE OBLIQUA**

I pensili con questo tipo di meccanismo necessitano per l'apertura di poco spazio libero sopra il mobile grazie al movimento basculante dell'anta che si apre senza difficoltà applicando poca forza anche in presenza di frontali pesanti. Con l'arresto progressivo le ante si fermano in qualsiasi posizione; in questo modo la maniglia è sempre facilmente raggiungibile. La chiusura è ammortizzata ed è possibile regolare la forza di tenuta in base al peso del frontale.

VERTICAL OPENING OBLIQUE

Wall units that mount this type of mechanism require little clearance above the cabinet thanks to the swivelling movement of the door that can be easily opened by applying slight pressure, even with heavy fronts. The doors stop in any position thanks to the gradual stopping movement; in this way, the handle is always easily accessible. The closing movement is cushioned and the closing force can be adjusted according to the weight of the front door.



**DI SERIE  
STANDARD**



**MOTORIZZATO  
SERVO-DRIVE  
SERVO-DRIVE  
MOTORISED  
(Opz.007)**

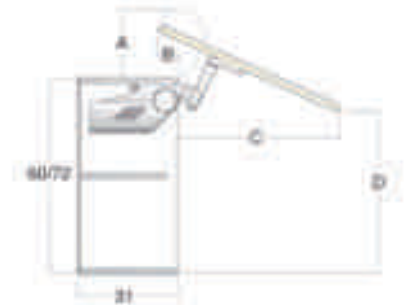

	A	B	C	D
H 60	18	9,6	46,5	53,5
H 72	18	9,6	57	61

**APERTURA VERTICALE**

L'anta ad apertura verticale, potendo essere sollevata completamente verso l'alto, consente un accesso totale all'interno del pensile. Ideale per l'impiego in mobili a colonna per nascondere ad esempio apparecchi elettrici, o pensili con corpi mobili sovrastanti, ha la chiusura ammortizzata e la possibilità di regolare la forza di tenuta in base al peso del frontale.

VERTICAL OPENING

Doors with vertical opening movement can be fully raised to fully access the inside of the wall unit.

Ideal for use on column units to conceal electrical appliances for examples, or on wall units surmounted by mobile units.

The closing movement is cushioned and the closing force can be adjusted according to the weight of the front door.



**DI SERIE  
STANDARD**



**MOTORIZZATO  
SERVO-DRIVE  
SERVO-DRIVE  
MOTORISED  
(Opz.007)**



	A	B	C	
H 36	34	23,5	34,5	
H 48	43	28,5	43,5	



# PENSILI APERTURA A PACCHETTO

WALL UNITS FOLDING DOORS

## PENSILE CON APERTURA ANTE A PACCHETTO

Il meccanismo d'apertura ante a pacchetto è idoneo sia sul pensile H 72 che H 96; la regolazione della forza di apertura può essere impostata in modo esatto in base ai pesi dei frontali, la chiusura è ammortizzata e la cerniera centrale clip si contraddistingue per l'innovativa tecnologia che garantisce la sicurezza per le dita.

WALL UNIT WITH LIFT-UP FOLDING DOOR

The lift-up folding door opening mechanism is suitable for wall units with H 72 or H 96; the opening force can be adjusted precisely according to the weight of the fronts, while the closing movement is cushioned and the central clip-on hinge features innovative technology for safeguarding the fingers.



H 72



H 96

### DI SERIE STANDARD



	A	B	C
H 72	16,5	54	41
H 96	20	69	53

### MOTORIZZATO SERVO-DRIVE SERVO-DRIVE MOTORISED (Opz.007)



### SCHEMA MONTAGGIO LIMITATORE LIMITER INSTALLATION DIAGRAM

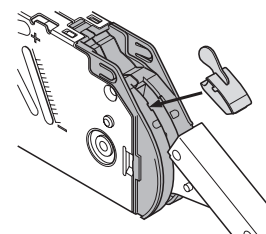

Per evitare l'interferenza dell'anta in fase di apertura con cornici o mensole, si può richiedere il limitatore dell'angolo di apertura cod. 5620005

In order to avoid that the door interferes with cornices or shelves during the opening movement, it is possible to request an opening angle limiter: code 5620005

# PENSILI RIBALTA CHIUSURA BLUMOTION

FLAP DOOR WALL UNITS BLUMOTION CLOSING SYSTEM

## PENSILE CON APERTURA A RIBALTA

Le ante aprendosi verso l'alto consentono di avere un' ampia visione d'insieme all'interno del mobile. In questo modo è possibile un comodo accesso agli oggetti contenuti al suo interno e, dal punto di vista ergonomico, molto vantaggioso. La regolazione della forza di apertura può essere impostata in modo esatto in base al peso del frontale. Grazie all'arresto progressivo le ante si fermano in qualsiasi posizione; in questo modo la maniglia è sempre facilmente raggiungibile. La chiusura è ammortizzata e un'unica manovra è sufficiente per regolare il frontale tridimensionalmente grazie all'assenza di cerniere e al sistema di aggancio clip.

WALL UNIT WITH FLAP DOOR

The doors that open upwards guarantee ample overall visibility inside the cabinet. In this way, all objects housed inside the cabinet can be comfortably accessed, making the system highly advantageous from an ergonomic perspective. The opening force can be adjusted precisely depending on the weight of the front. The doors stop in any position thanks to the gradual stopping movement; in this way, the handle is always easily accessible. The closing movement is cushioned and a single manoeuvre is required to three-dimensionally adjust the front, thanks to the clip-on system and the absence of hinges.



### DI SERIE STANDARD



	A	B	C
H 36	11,5	3,5	37
H 48	15	3,5	49
H 60	18,5	3,5	61

Per evitare l'interferenza dell'anta in fase di apertura con cornici o mensole, si può richiedere il limitatore dell'angolo di apertura cod. 5620010

In order to avoid that the door interferes with cornices or shelves during the opening movement, it is possible to request an opening angle limiter: code 5620010

### MOTORIZZATO SERVO-DRIVE SERVO-DRIVE MOTORISED (Opz.007)



SCHEMA MONTAGGIO LIMITATORE  
PER RIBALTA H 36  
FLAP DOOR LIMITER INSTALLATION  
DIAGRAM H 36

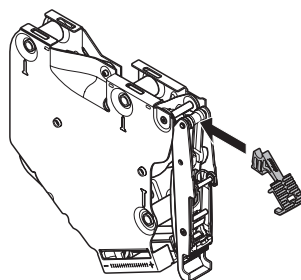

SCHEMA MONTAGGIO LIMITATORE  
PER RIBALTA H 48  
FLAP DOOR LIMITER INSTALLATION  
DIAGRAM H 48

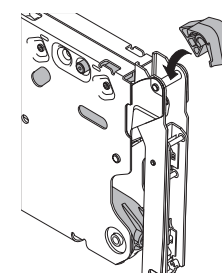

# TIPOLOGIE CAPPE CAMINO

CHIMNEY HOOD TYPES

## cappa tipo "S" vedi pag. 68

chimney type "S"  
see page 68



## cappa tipo "SN" vedi pag. 76

chimney type "SN"  
see page 76



## cappa tipo "S2" vedi pag. 69

chimney type "S2"  
see page 69



# TIPOLOGIE CAPPE CAMINO

CHIMNEY HOOD TYPES

## cappa tipo "F1" vedi pag. 70

chimney type "F1"  
see page 70



## cappa tipo "F1N" vedi pag. 77

chimney type "F1N"  
see page 77



## cappa tipo "B4" vedi pag. 71

chimney type "B4"  
see page 71



## cappa tipo "B4N" vedi pag. 78

chimney type "B4N"  
see page 78





# TIPOLOGIE CAPPE CAMINO

CHIMNEY HOOD TYPES

## cappa tipo "F2"

vedi pag. 74

chimney type "F2"

see page 74



## cappa tipo "E"

vedi pag. 73

chimney type "E"

see page 73



# TIPOLOGIE CAPPE CAMINO

CHIMNEY HOOD TYPES

## cappa tipo "P1" vedi pag. 79

chimney type "P1"  
see page 79



## cappa tipo "P2" vedi pag. 80

chimney type "P2"  
see page 80



## cappa isola vedi pag. 81

chimney island  
see page 81



## cappa isola con piastrelle vedi pag. 81

chimney island with tiles  
see page 81



# SCHEMA CAPPA CAMINETTO AD ANGOLO

CORNER CHIMNEY HOOD DIAGRAM



# SCHEMA CAPPAMINETTO AD ANGOLO

CORNER CHIMNEY HOOD DIAGRAM

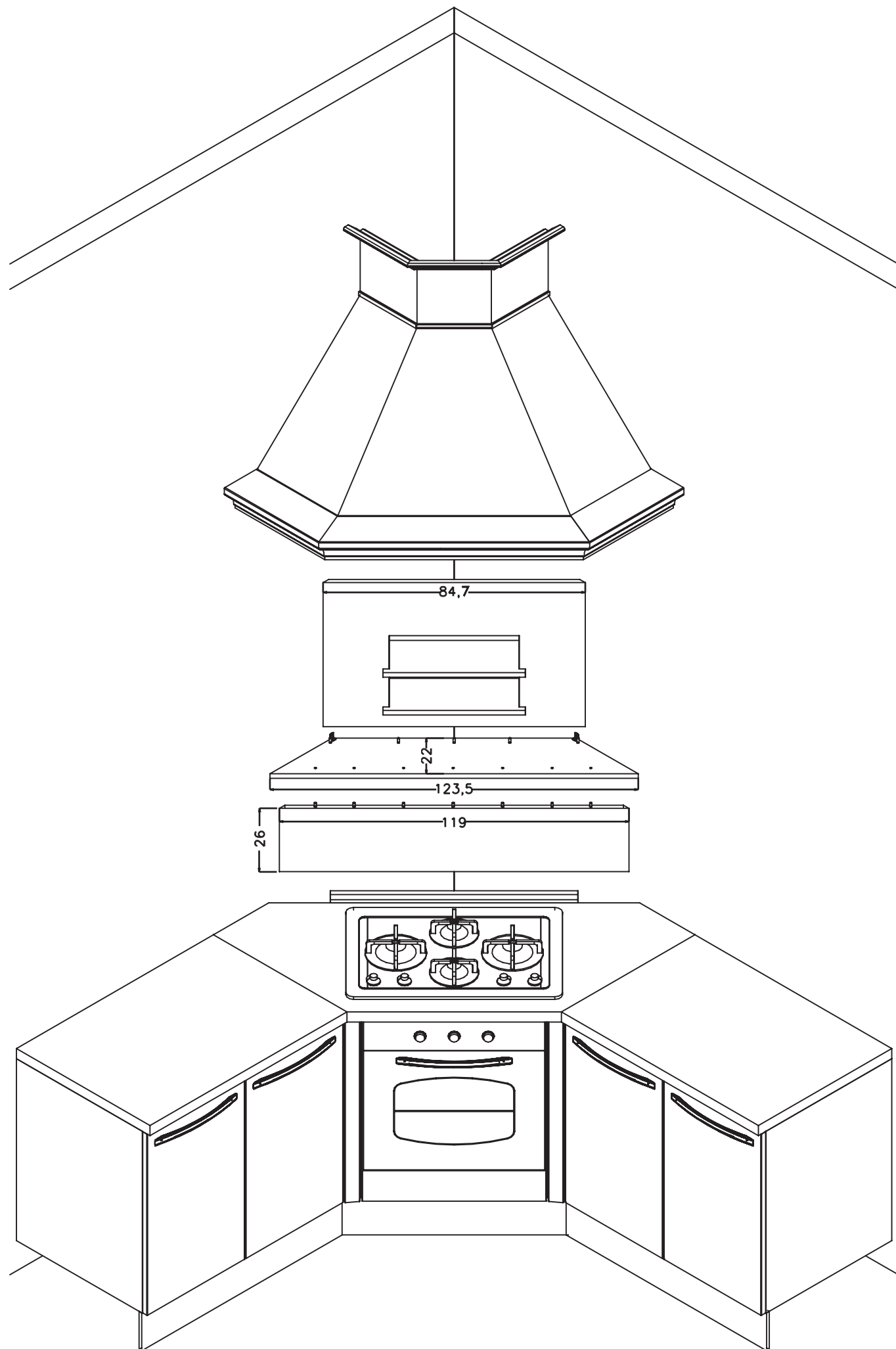



# SCHEMA CAPPA CAMINETTO AD ANGOLO

CORNER CHIMNEY HOOD DIAGRAM

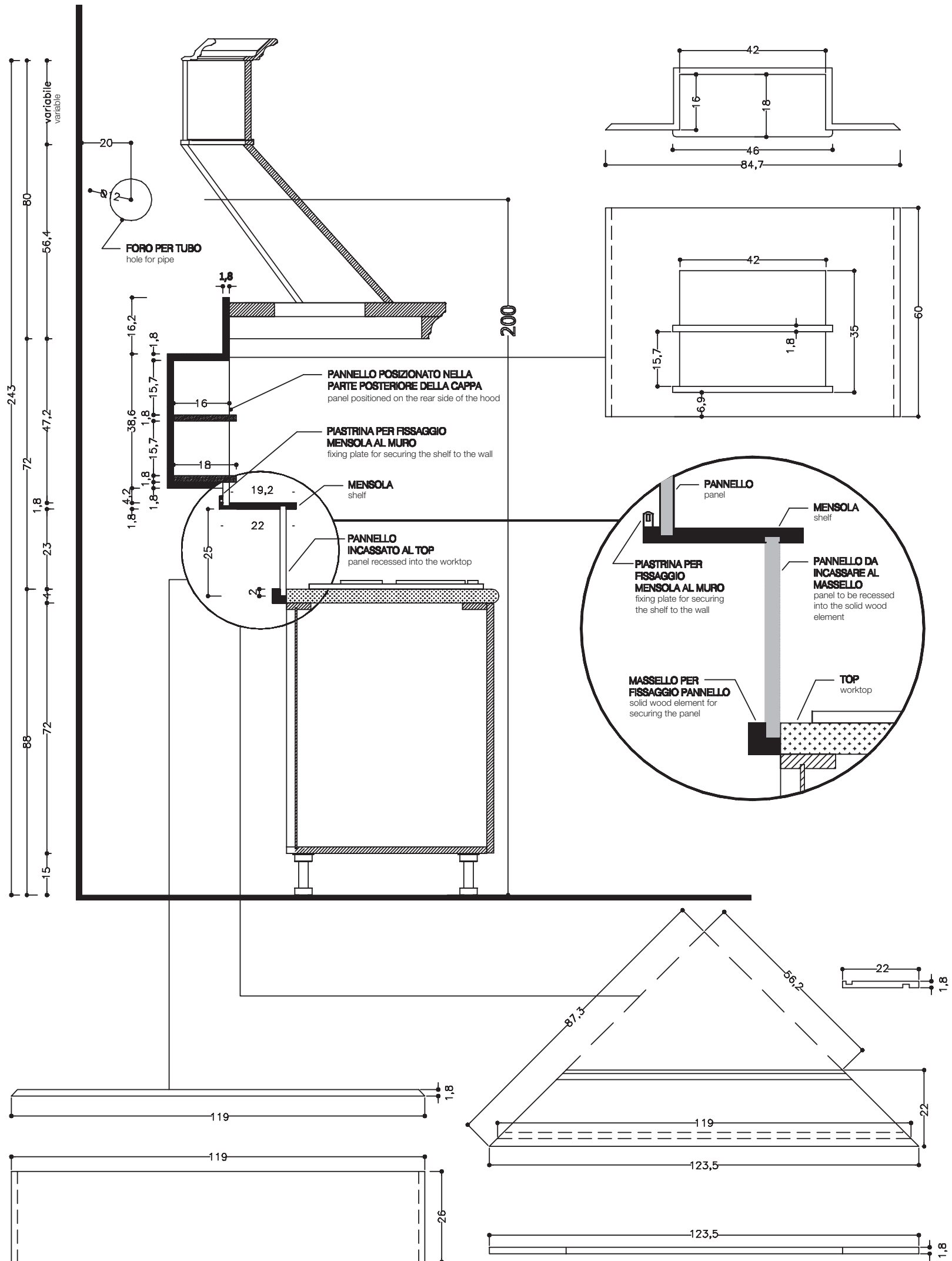

## Serie: SASSI DEL PIAVE

Range: SASSI DEL PIAVE



botticino  
(opz.120)  
botticino



travertino noce  
(opz.125)  
walnut travertine



scabas  
(opz.110)  
scabas



giallo dorè  
(opz.112)  
golden yellow



travertino chiaro  
(opz.127)  
light travertine

# COLORI EFFETTO MURO PER CAMINI CAPPE

WALL EFFECT COLOURS FOR CHIMNEY HOODS



**BIANCO**  
a rullo (opz.R006)  
frattonato (opz.F006)

WHITE  
for roller (code R006)  
for trowel (code F006)



**CIPRIA**  
a rullo (opz.R114)  
frattonato (opz.F114)

PALE PINK  
for roller (code R114)  
for trowel (code F114)



**TERRA BRUCIATA**  
a rullo (opz.R173)  
frattonato (opz.F173)

SCORCHED EARTH  
for roller (code R173)  
for trowel (code F173)

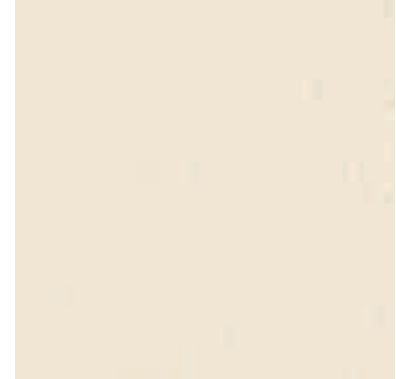

**PANNA**  
a rullo (opz.R012)  
frattonato (opz.F012)

CREAM  
for roller (code R012)  
for trowel (code F012)



**ROSA ANTICO**  
a rullo (opz.R035)  
frattonato (opz.F035)

ANTIQUÉ PINK  
for roller (code R035)  
for trowel (code F035)



**MELONE**  
a rullo (opz.R045)  
frattonato (opz.F045)

MELON  
for roller (code R045)  
for trowel (code F045)

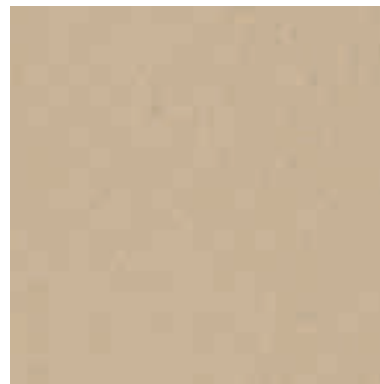

**CORDA**  
a rullo (opz.R125)  
frattonato (opz.F125)

JUTE  
for roller (code R125)  
for trowel (code F125)

# RILEVAZIONE DEL FUORI SQUADRO

OUT-OF-PLUMB MEASUREMENTS

Per le composizioni ad angolo è importante rilevare l'esatta misura dell'angolo per il corretto montaggio della cucina.

Si tenga presente che la diagonale dell'angolo di 90° è di cm 141,4 (100x100).

For corner compositions, it is important to measure the corner precisely to ensure that the kitchen is correctly installed.

Bear in mind that diagonal segment opposite the 90° corner measures 141,4 (100x100)

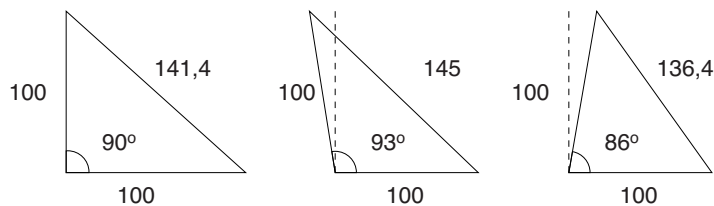

Riportiamo di seguito una tabella in cui sono riportate rispettivamente la misura dell'angolo con la diagonale corrispondente.

Below is a table indicating, respectively, the size of the corner and the length of the corresponding diagonal segment

## ANGOLI SUPERIORI A 90° CORNERS EXCEEDING 90°

angolo in gradi corner in degrees	diagonale in cm diagonal segment in cm
90	141,4
90,5	142
91	142,6
91,5	143,3
92	143,9
92,5	144,5
93	145
93,5	145,7
94	146,3
94,5	146,9
95	147,4
95,5	148
96	148,6
96,5	149,2
97	149,8
97,5	150,4
98	150,9
98,5	151,5
99	152,1
99,5	152,6
100	153,2

## ANGOLI INFERIORI A 90° CORNERS BELOW 90°

angolo in gradi corner in degrees	diagonale in cm diagonal segment in cm	aumento in cm della composizione increase in cm of the composition
90	141,4	-
89,5	140,8	-
89	140,2	-
88,5	139,5	-
88	138,9	-
87,5	138,3	-
87	137,7	-
86,5	137	-
86	136,4	-
85,5	135,8	1,5
85	135,1	2
84,5	134,5	2,5
84	133,8	3
83,5	133,2	3,5
83	132,5	4,5
82,5	131,9	5
82	131,2	6
81,5	130,5	6,5
81	129,9	8
80,5	129,2	8,5
80	128,5	9,5
79,5	127,9	10
79	127,2	10,5
78,5	126,5	11,5
78	125,8	12
77,5	125,2	12,5
77	124,5	13,5

## ANGOLO MAGGIORE DI 90° CORNER EXCEEDING 90°

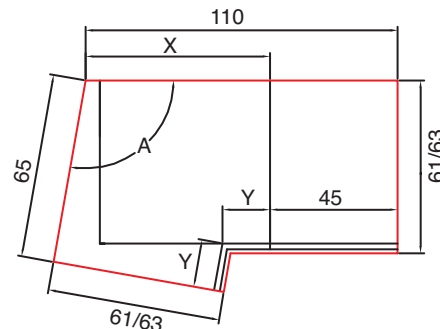

Nel caso in cui abbiamo un angolo maggiore di 90° le misure della base ad angolo non cambiano, ma viene aumentata la misura del massello angolare (Y).

N.B. per angoli maggiori di 110° interpellare sempre il nostro Ufficio Tecnico.

In case of corners exceeding 90°, the dimensions of the corner base unit do not change, while the size of the corner solid wood section (y) increases.

Note: for corners exceeding 110°, always contact our Technical Department.

## ANGOLO COMPRESO TRA 86° E 90° CORNER BETWEEN 86° AND 90°

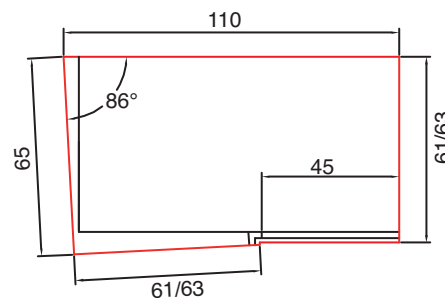

Nel caso in cui abbiamo un angolo compreso tra 86° e 90° le misure della base ad angolo non cambiano, ma viene diminuita la misura del massello angolare (Y).

Inoltre è necessario tener presente che di seguito alla base ad angolo non possono essere inserite basi forno, cassetiere, lavastoviglie, ma esclusivamente basi con anta incernierata sul fianco.

In case of corners between 86° and 90°, the dimensions of the corner base unit do not change, while the size of the corner solid wood section (y) decreases. Moreover, it is important to remember that oven base units, drawer units or dish-washers cannot be inserted next to the corner base unit, but only base units that have the door hinges on the side.

## ANGOLO MINORE DI 86° CORNER BELOW 86°

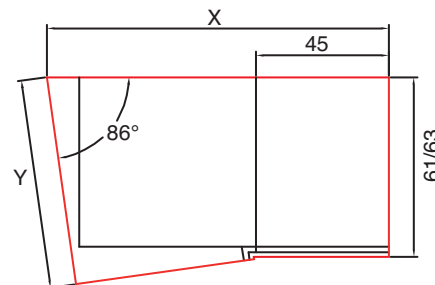

Quando l'angolo è inferiore a 86° la lunghezza della composizione viene aumentata in rapporto all'ampiezza dell'angolo (vedi tabella) per questo motivo è importante specificare nell'ordine le misure delle pareti da arredare.

Inoltre è necessario tener presente che di seguito alla base ad angolo non possono essere inserite basi forno, cassetiere, lavastoviglie, ma esclusivamente basi con anta incernierata sul fianco.

When the corner measures below 86°, the length of the composition increases in relation to the size of the corner (see table); for this reason, in the order it is important to specify the measurements of the walls to be furnished. Moreover, it is important to remember that oven base unit, drawer units or dish-washers cannot be inserted next to the corner base unit, but only base units that have the door hinges on the side.



# RILEVAZIONE DEL FUORI SQUADRO

OUT-OF-PLUMB MEASUREMENTS

**Nelle composizioni lineari dove a inizio o fine composizione c'è una parete fuori squadra prendere sempre la misura della diagonale e comunicarla al nostro Ufficio Tecnico.**

In regards to linear compositions that have an out-of-plumb wall at the beginning or end of the composition, remember to always take the measurement of the diagonal segment and notify it to our Technical Department.

**Nell'esempio n. 1 l'angolo è maggiore di 90° e quindi occorre aumentare il top davanti; la stessa cosa si deve fare per le basi, mettendo una fascia di tamponamento.**

In example no.1, the corner exceeds 90°, thus the worktop must be extended on the front; the same applies to base units, where a filler panel must be added.

**Nell'esempio n. 2 l'angolo è minore di 90° occorre accorciare la composizione; questo vale sia per il top che per le basi.**

In example no.2, the corner is below 90°, therefore the composition must be shortened; this applies to both the worktop and base units.

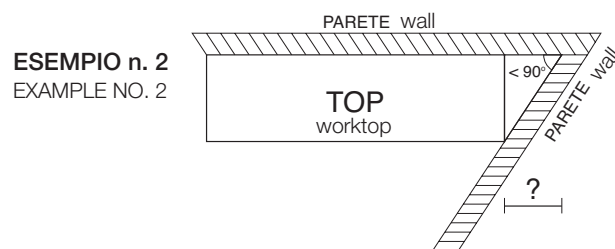
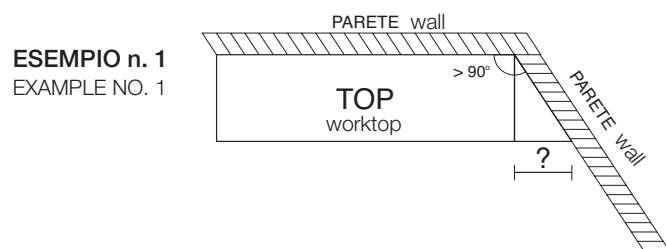

**Nel caso in cui nell'angolo ci sia un pilastro, occorre rilevare oltre alle misure del pilastro anche le 3 diagonali come riportato nello schema (d1-d2-d3).**

In case there is a pillar in the corner, we need to have the 3 diagonal measures as shown in the scheme (d1-d2-d3) other than the measures of the pillar itself

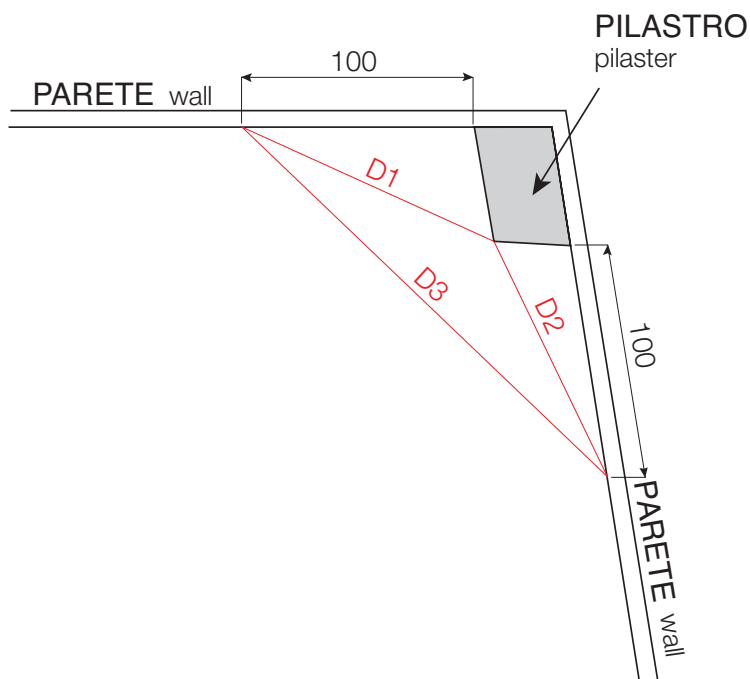

# SCHEMA BASI E TOP TERMINALI

DIAGRAMS OF END BASE UNITS AND WORKTOPS

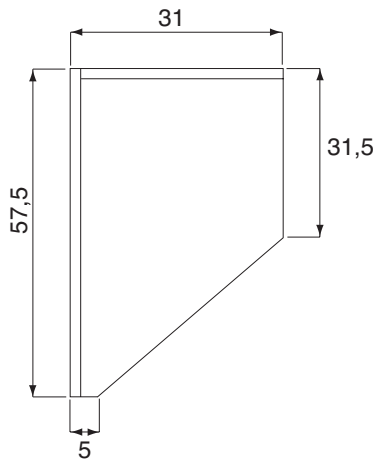

**BASE TERMINALE  
a giorno tipo "C"**  
Type "C"  
open END BASE UNIT

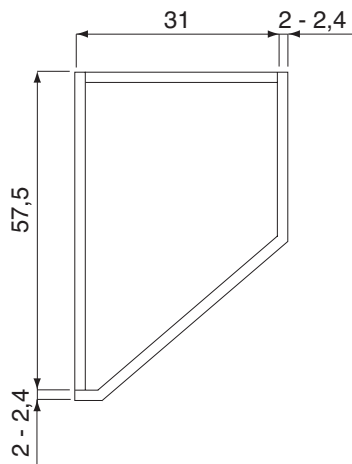

**BASE TERMINALE  
con anta tipo "C"**  
END BASE UNIT  
with type "C" door

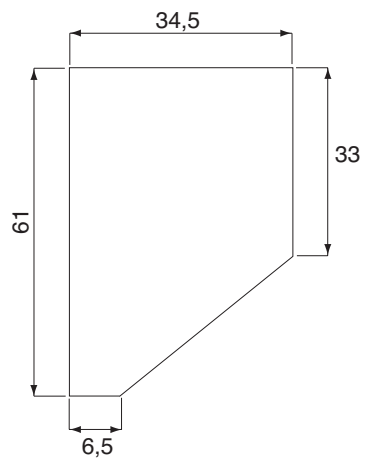

**TOP PER BASE TERMINALE  
a giorno tipo "C"**  
WORKTOP FOR type "C"  
open END BASE UNIT

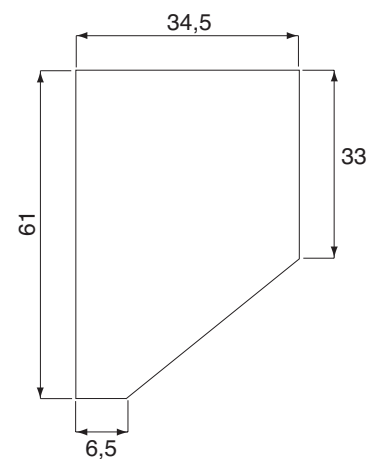

**TOP PER BASE TERMINALE  
con anta tipo "C"**  
WORKTOP FOR END BASE UNIT  
with type "C" door

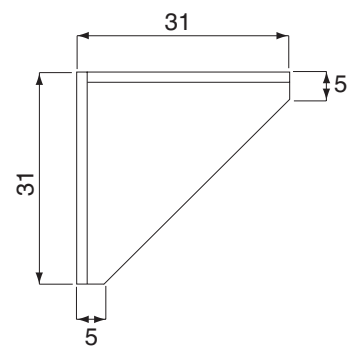

**PENSILE TERMINALE  
a giorno tipo "C"**  
Type "C"  
open END WALL UNIT

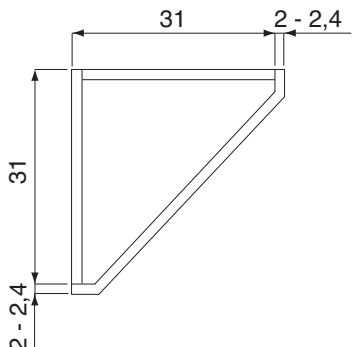

**PENSILE TERMINALE  
con anta tipo "C"**  
END WALL UNIT  
with type "C" door

## POSIZIONAMENTO BARRA PER FISSAGGIO PENSILI

### POSITIONING OF THE WALL UNIT FIXING STRIP

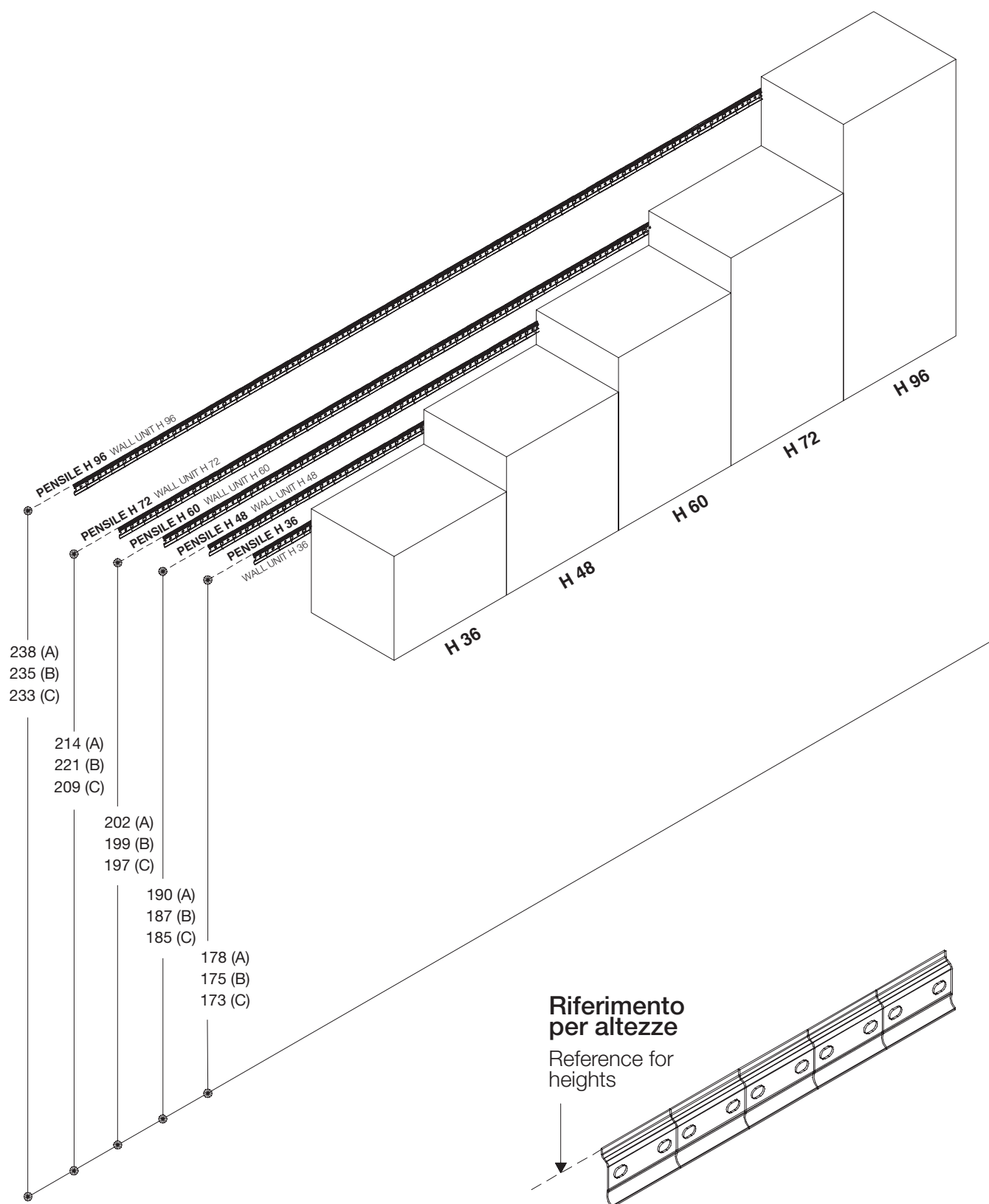

**(A) Zoccolo H 15**

(A) Plinth H 15

**(B) Zoccolo H 12**

(B) Plinth H 12

**(C) Zoccolo H 10**

(C) Plinth H 10

**N.B.: in prossimità dell'attaccaglia, mettere minimo 2 fischer vicini, per dare una maggiore tenuta**

Note: place at least 2 rawl plugs close together near fixing elements to increase the load bearing capacity

# SCHEMA DI ALLACCIO IMPIANTO ELETTRICO IDRICO E GAS

POWER, WATER AND GAS NETWORKS CONNECTIONS DIAGRAM

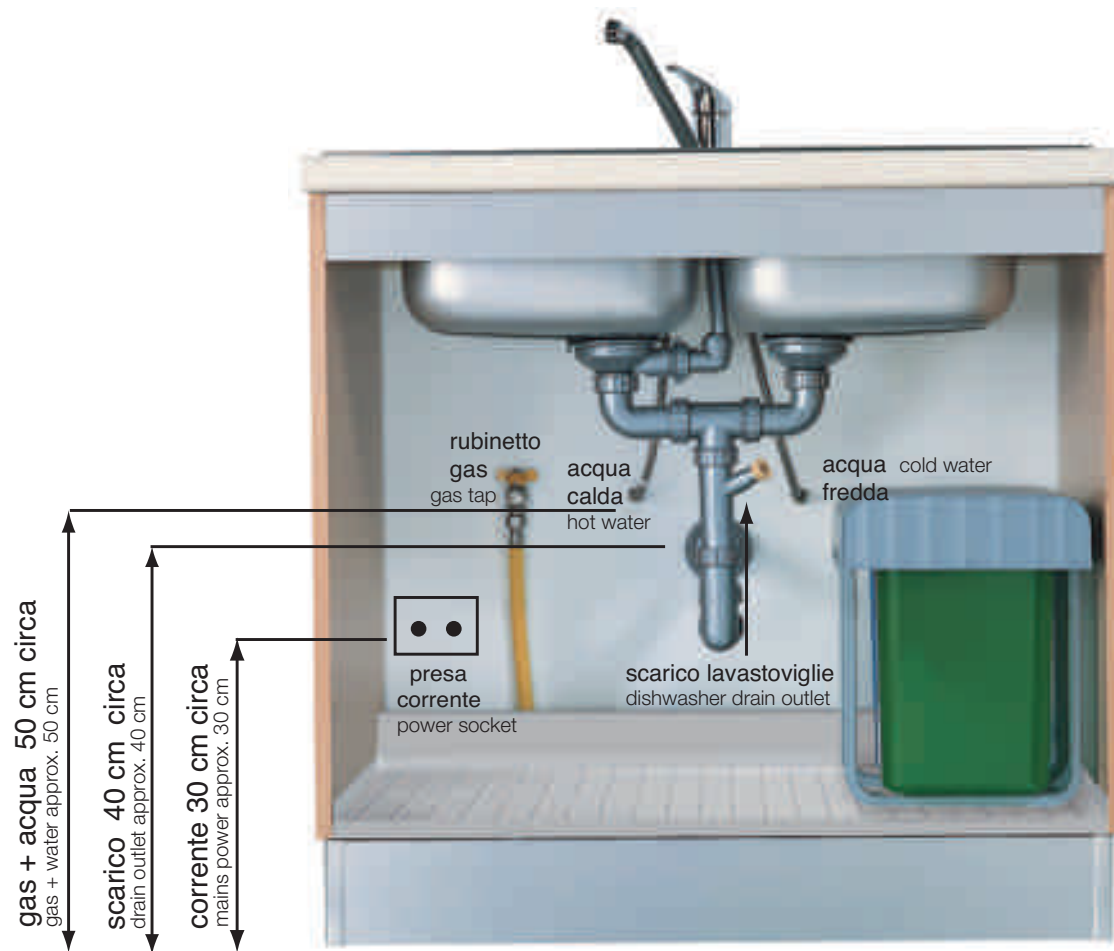

**SOTTOLAVELLO CON ANTE**  
SINK BASE UNIT WITH DOORS

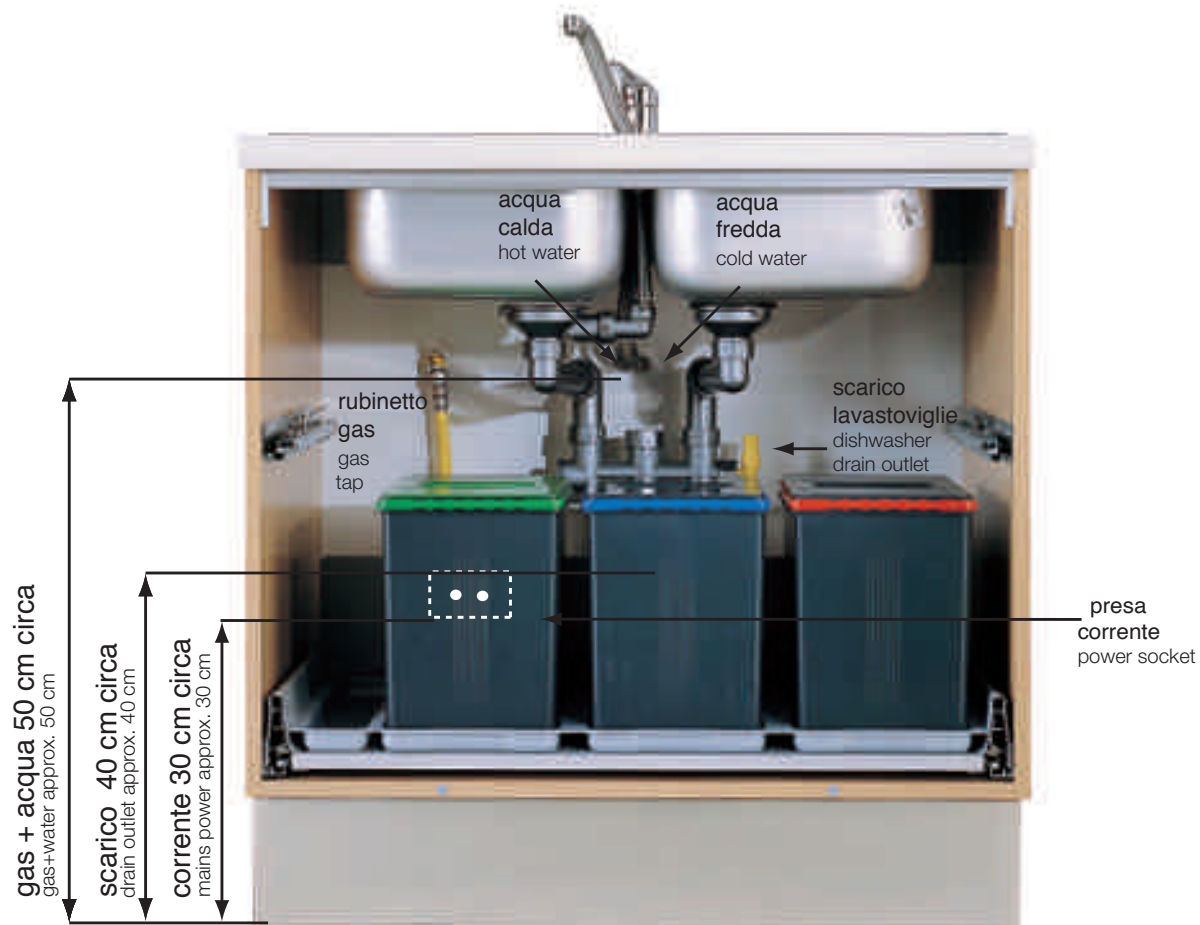

**SOTTOLAVELLO 2 CESTONI CON SIFONE SALVASPAZIO**  
SINK BASE UNIT WITH 2 DEEP DRAWERS AND SPACE-SAVER DRAIN PIPING



# INFORMAZIONI PER LA PROGETTAZIONE

DESIGN INFORMATION

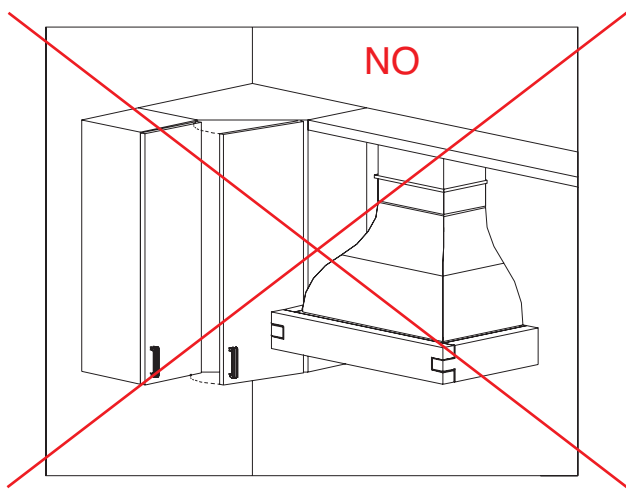

## CAPPA A RIDOSSO DEL PENSILE ANGOLO HOOD ADJACENT TO CORNER WALL UNIT

**Consigliamo di non posizionare una cappa d'arredamento a fianco di un pensile angolo 65x65 diagonale in quanto impedisce la corretta apertura dell'anta.**

It is advisable not to install a design hood adjacent to a 65x65 cm diagonal corner wall unit, as this interferes with the opening of the wall unit door.

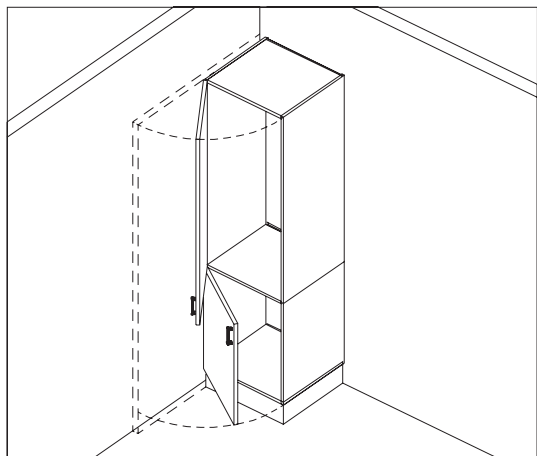

## FRIGORIFERO VICINO AL MURO REFRIGERATOR NEAR THE WALL

**Nel caso che una colonna frigorifero sia posizionata vicino ad una parete occorre lasciare uno spazio di almeno 4 cm per consentire una totale apertura dell'anta della colonna e l'estrazione totale dei cassetti dell'elettrodomestico.**

If a fridge column is positioned close to a wall, leave at least 4 cm free to ensure the full opening of the column door and the full extension of the appliance's drawers.

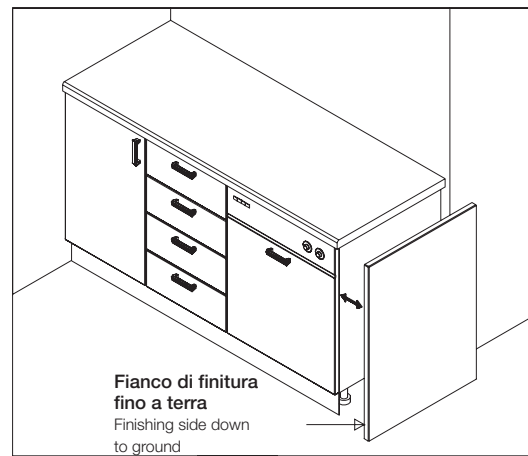

## ELETTRODOMESTICO A FINE COMPOSIZIONE HOUSEHOLD APPLIANCE AT THE END OF A COMPOSITION

**Nel caso che la lavastoviglie o la lavatrice sia posizionata a fine composizione occorre l'uso di un fianco di finitura fino a terra, considerando lo spessore dello stesso per determinare la lunghezza del top.**

If a dishwasher or washing machine is placed at the end of a composition, it is necessary to install a finishing side down to ground; the latter's thickness must be considered when determining the length of the worktop.

# INFORMAZIONI PER LA PROGETTAZIONE

DESIGN INFORMATION

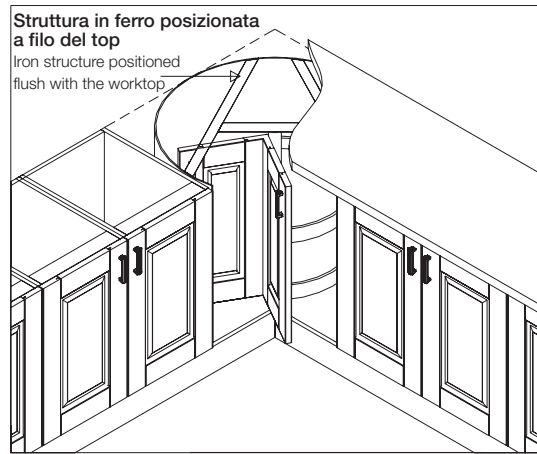

## BASE ANGOLO 95x95 2 ANTE GIREVOLI 95x95 CORNER BASE UNIT WITH 2 SWIVEL DOORS

**Non è possibile inserire gli elettrodomestici.**  
Household appliances cannot be inserted

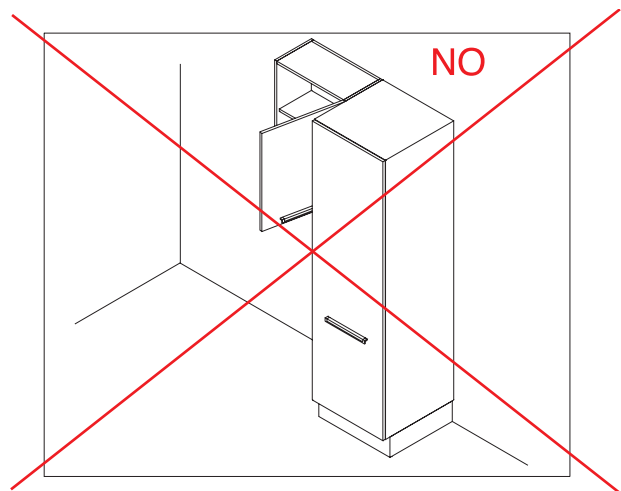

## PENSILE ACCANTO ALLA COLONNA WALL UNIT NEXT TO A COLUMN

**Evitare il posizionamento del pensile verso la colonna, in quanto non si ha una completa apertura dell'anta e si rischia di danneggiare il fianco.**

Avoid placing a wall unit near the column, as this prevents the complete opening of the door and may cause the side to be damaged

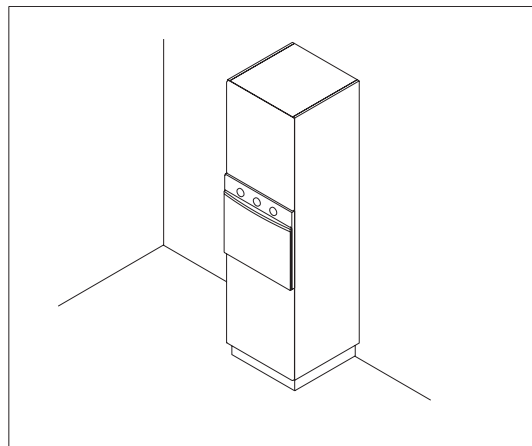

## FORNI STATICI SENZA VENTILAZIONE NON-VENTILATED STATIC OVENS

**Evitare l'abbinamento dei forni statici senza ventilazione di raffreddamento nelle colonne, poiché il calore e il vapore emanati durante il funzionamento dell'elettrodomestico possono danneggiare le antine e la struttura della colonna.**

Avoid inserting non-ventilated static ovens in columns, as the heat and steam generated during the appliance's operation may damage the column's doors and carcass.

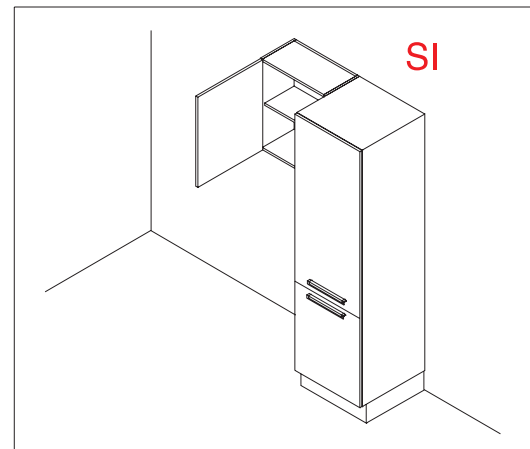

**Si consiglia di utilizzare il pensile con l'apertura dell'anta opposta alla posizione della colonna con cerniere a 180°**

It is advisable to use a wall unit with a door that opens in the opposite direction to the column's position, with 180° hinges.

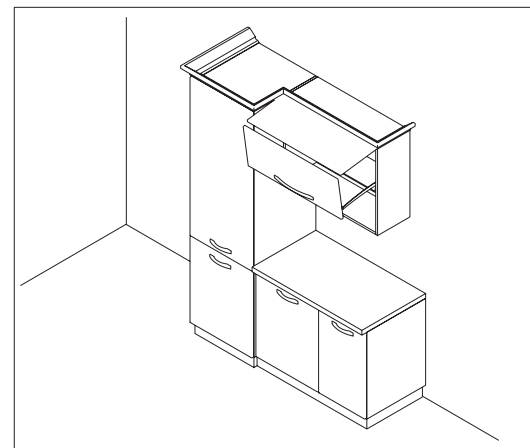

## PENSILE A PACCHETTO WALL UNIT WITH LIFT-UP FOLDING DOOR

**Per evitare nei pensili con apertura a pacchetto l'interferenza dell'anta in fase di apertura con cornici o mensole si può richiedere il limitatore dell'angolo di apertura cod.5620005**

In order to avoid that the lift-up folding door interferes with cornices or shelves during the opening movement, it is possible to request an opening angle limiter code 5620005





# MODULARITÀ E COMPONIBILITÀ MODULARITY AND FITTING SOLUTIONS

